

HIGH TEMPERATURE CAMERA

sonda^{tec} Sondatec P integrated system

Air cooled integrated vision system

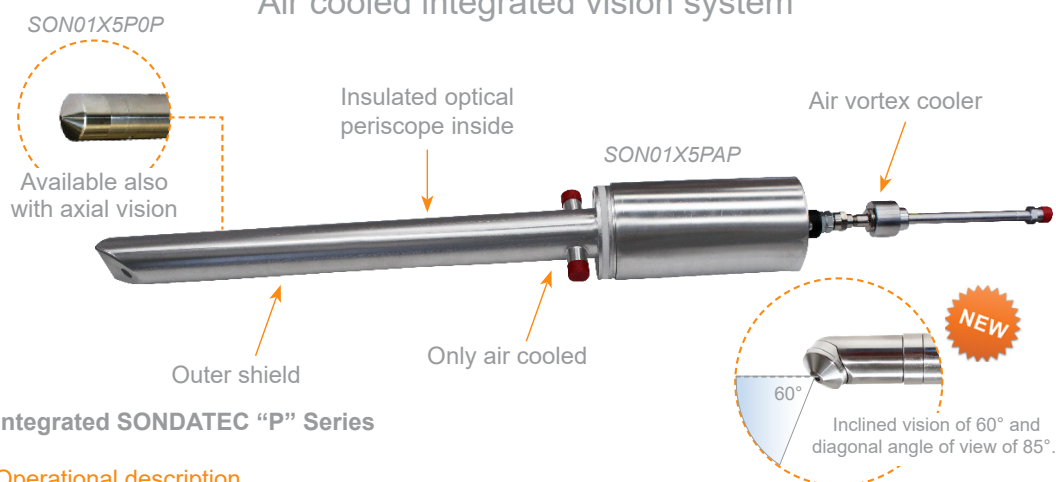

Integrated SONDATEC "P" Series

Operational description

Telea Tecnovision has realized a range of integrated products that combines the performance of SONDATEC-P housings with the efficiency of IP CAMTEC cameras.

CAMTEC high-temperature IP cameras provide clear, crisp images of the combustion process in boilers, kilns, furnaces, incinerators and other combustion chambers. With the real-time image provided, engineers and operators can monitor the proper flow of fuel and raw materials, reduce emissions, reduce fuel consumption, speed up boiler light off and improve safety.

CAMTEC IP cameras are native network camera based on a high resolution HD CMOS image sensor with resolution up to 1280x720pixel. Within a powerful microprocessor many image settings can be done to produce high quality video even in the most challenging lighting conditions present in the high temperature Industrial process.

The removable IR-CUT filter build in the camera allow to use cameras also in very low light conditions. Multi-streaming and multi-encoding for MJPEG, H.264 can guarantee a wide range of solutions for view, stream and record the images coming from CAMTEC IP cameras over any Ethernet network.

SONDATEC-P housings are 600 mm long with a diameter equal to 50 mm. They are typically endowed with axial or inclined vision and they can allow diagonal angles of vision up to 105°.

Full Air cooling solution requires special attention for the outer shield materials. AISI310 grade steel has been used for maximum results.

SONDATEC-P camera housings employ a special double air cooling system that allows operation with temperatures up to 1800°C. Standard service quality pressurized air circuit allows the external cooling meanwhile a cold instrumentation flow air is produced by a vortex cooled device.

SONDATEC-P housings are "pressurized": an integral compressed air system supplies clean air (or appropriate gas) for cooling and particulate removal from the lens. In such a way the lens doesn't require any expensive protection glass, crystal and protection porthole. A constant supply of clean air is essential for proper camera operation and protection: GFATEC series represent an effective filtration system able to remove contaminants and to provide high quality clean air in industrial environments.

SONDATEC-P housings may be provided with retraction devices (INTEC series): in case of system failure, or failure of the cooling supply, the retraction device automatically removes the housing from the furnace and seals the furnace porthole.

Aware of the difficulties and of the critical urgencies that characterize industrial environments, the settings, operation and control of CAMTEC IP series cameras can be easily done from a PC connected on the same network, through a browser and the camera's web server.

Technical specification

Diameter:	50 mm
Length of penetration:	500 mm
Angle of vision:	axial or inclined (60°), max horizontal angle: 105°
Electrical connections:	armoured flexible tube

The "T TELEA" brand and "T" logo are registered trademark of Telea Tecnovision S.r.l. Specifications may be subject to change for improvement without prior notice.



Head Office and Factory:
Telea Tecnovision Srl
Italy
tel. +39 02 9952517
fax. +39 02 40700322
telea@telea.com
www.telea.com

HIGH TEMPERATURE CAMERA

Air for cooling and cleaning lens

Connection:	1/4" M-BSPP (vortex)
Temperatures IN:	40°C max
Pressure entry:	6 bar, up to maximum 8 bar (3*)
Consumption:	@6 bar typical 30 Nm³/h for release 2000btu/h (3*)
Quality:	Instrumental Air ISO 8573-1Classe 1.2.1

Air for cooling external shield

Connection:	2x1/2" M-BSPP
Pressure entry:	2 bar
Consumption:	Typical 20 Nm³/h

Technical Specifications		
SENSOR	Sensor type	1/3" CMOS
	Resolution	Full HD 1920x1080
	Day/Night	Movable IR-cut filter
	Minimum Illumination	Color: 0,65Lux (F1.2/33ms), Day/Night: 0.15Lux (F1.2/33ms)
LENS	Type	DC iris drive
	Focal lens	Various (see the table below)
	Video compression	H.264 (MP); M-JPEG; MPEG-4
	Streaming	Dual streaming for MJPEG, H.264 or MPEG-4; VBR and CBR for MPJEG and MPEG-4; VBR, CBR and CVBR for H.264, multicast and unicast
	Processor	Multimedia video processor, FPGA
	Memory	256MB (RAM), 64MB (Flash)
	Digital Input/Ouput	3 (Configurable)
	Alarm management	Ring buffer for pre and post alarm images, microSDHC card slot for local storage; events triggered by motion detection or external input; image upload over FTP, e-mal or HTTP;
	Protocols	TCP/IP, HTTP, FTP, UDP, ICMP, ARP, DHCP, NTP, RTP, RTSP, RTCP, SMTP, IGMP, Zero Config, QoS Layer 3, SNMP
	Settings	AOIs, Privacy Masks, Text Overlay, Electronic PTZ via AOI (API), Anti-Flicker, 180° Image rotation, Electronic Shutter, White Balance, BLC, Exposure area, Automatic Gain
	Connectors	RJ-45 connector for 10/100 Base-T Ethernet, full or half duplex; 8-pin terminal for DC power; digital I/O; RS-485
	POWER	Power Supply
Power Consumption		3.2 W

Correlated products

INT02X_ INTEC retraction device

Available models (Part Number Configurator)

0 1 X A B C D

0	1	X	A	B	C	D	
			Length [mm]	Series	View / Field of vision	Type of camera inside	
			1 = 1000/1200	S = Air & water cooling	Part number configurator "C"	A = Analog	
			3 = 300	P = Air cooling		View	P = IP
			4 = 4000	G = Air cooling	Field of vision		
			5 = 500*		0	Axial	-
			6 = 1600		A		bottom
			7 = 700		B	Inclined 60°	up
					C		left
					D		right

Notes

*Length of penetration

(3*) Data are indicative and depend of process' temperature and application. For more informations, please contact our engineers.

The "T TELEA" brand and "T" logo are registered trademark of Telea Tecnovision S.r.l. Specifications may be subject to change for improvement without prior notice.



Head Office and Factory:
Telea Tecnovision Srl
Italy
tel. +39 02 9952517
fax. +39 02 40700322
telea@telea.com
www.telea.com